

Perlite Insulating Concrete Roofdecks

Non-combustible, Superior Fire Ratings, Nailable Roofing Base, Lightweight & Durable, Cost Effective Reroofing base, Superior Thermal Performance, Smooth Slope-to-drain Surface

DESCRIPTION, PROPERTIES, BENEFITS

Perlite concrete roof deck insulation is an ideal base for built-up and single ply roofing systems. It has superior wind and fire resistance over other roof insulation materials and with the addition of polystyrene insulation board sandwiched in the perlite concrete, high thermal resistance values, are economically achieved.

Positive drainage is easily accomplished by varying the thickness of perlite concrete or by stair stepping different thicknesses of polystyrene insulation board and then covering it with a uniform layer of perlite concrete.

Perlite concrete insulation may be placed over vented or slotted galvanized steel decking, precast or poured-in-place concrete, or existing roofing materials providing a seamless, smooth, and hard surface ready for roofing. If exposed to water it will not deteriorate.

REROOFING BASE

Perlite concrete insulation is ideally suited for reroofing applications. It provides permanent, cost effective, slope-to-drain designs with high R values over flat and often irregular substrates found in remodeling projects. Using a perlite concrete slurry coat the polystyrene insulation board is positively attached to the substrate and covered with a uniform layer of perlite concrete insulation. If the existing substrate is sound and capable of the additional loading required then the perlite concrete insulation can be applied to the existing roof thereby eliminating costly tearoffs.

TESTING AND APPROVALS

Perlite roof deck insulation systems have been tested and approved for wind and fire ratings by Underwriters Laboratories, Factory Mutual, and other code authorities. The system is rated as non-combustible by Factory Mutual UZ. Design P-920 successfully achieved the first 2-hour rating for any system of this kind under full-scale fire conditions. Perlite concrete roof decks with polystyrene insulation board meet the criteria for U.L. Class 90 and FM 1-90 wind resistance.

TABLE 1 - CONVERSION FACTORS I-P/SI UNITS		
TO CONVERT FROM	TO	MULTIPLY BY
lb/ft ²	kg/m ²	4.882
lb/ft ³	kg/m ³	16.02
lb/in ²	bar	0.068947
inch	meter (m)	0.0254
ft ³	meter ³ (m ³)	0.02832
ft ²	meter ² (m ²)	0.0929
°F·ft ² h/Btu·in (R)	kelvin meter per watt (°K·m/W)	6.929
Btu·in/h·ft ² °F (U)	watt per meter kelvin (W/m·°K)	0.144
gallons	liters	3.785

TABLE 2 - R-VALUE, U-FACTOR and DEADLOAD TABLE - 1:6 MIX RATIO, 24-30 pcf PERLITE INSULATION

2 in. of Perlite Concrete Over Polystyrene Thickness, In.	DEPTH OF CORRUGATIONS									STRUCTURAL CONCRETE, 4 in.		
	26 ga. 15/16 inch			24 ga. 1-5/16 inch			22 ga. 1-1/2 inch			R ⁽¹⁾	U ⁽²⁾	D.L. ⁽³⁾
	R ⁽¹⁾	U ⁽²⁾	D.L. ⁽³⁾	R ⁽¹⁾	U ⁽²⁾	D.L. ⁽³⁾	R ⁽¹⁾	U ⁽²⁾	D.L. ⁽³⁾			
0	3.9	.187	5.87	4.1	.177	6.65	4.1	.180	6.85	3.1	.216	4.00
1	7.9	.106	6.20	8.2	.103	6.98	8.1	.104	7.18	7.2	.115	4.33
2	11.7	.075	6.28	12.0	.074	7.06	12.0	.074	7.26	11.0	.080	4.41
3	15.6	.058	6.36	15.9	.058	7.14	15.8	.058	7.34	14.9	.061	4.49
4	19.4	.048	6.44	19.7	.047	7.22	19.7	.047	7.42	18.7	.049	4.57
5	23.3	.040	6.52	23.6	.040	7.30	23.5	.040	7.50	22.6	.042	4.65
6	27.1	.035	6.60	27.4	.035	7.38	27.4	.035	7.58	26.4	.036	4.73

NOTES:

1. R values expressed as °F·ft²/h/Btu.
2. U factors expressed as Btu/h·ft²·°F. Includes air films and roofing.
3. Dead loads include weight of metal, polystyrene and perlite concrete roof insulation. Dead loads of structural concrete not included.
4. Insulation values are for summer conditions, heat flow down. To calculate winter conditions, heat flow up, subtract 0.39 from the R value, then add 1.5 for air films and roofing, and divide into 1

5. U factors are based on series-parallel heat flow calculations defined in the ASHRAE Handbook of Fundamentals and on test data by recognized, independent test laboratories. Thermal conductivities of roof deck components are based on 40°F mean temperature except perlite concrete which is based on 75°F.
6. Perlite concrete properties are based on constant thickness insulation. For sloped insulation, calcu-

late average thickness.
 7. The U factors shown are calculations based on thermal conductivity data derived from laboratory testing of dry materials in accordance with ASTM Specification C 177. The values shown are intended only as guidelines. Actual insulation performance for all materials and systems is affected by design of building, environment and installation and will be lower than calculated values.

PHYSICAL PROPERTIES/CALCULATIONS

Code Approvals and Guide References

- International Conference of Building Officials (ICBO)
- Building Officials Conference of America (BOCA)
- Southern Building Code Congress (SBCC)
- South Florida Building Code
- Federal Construction Guide Specification FCGS 03501
- US Army Corps of Engineers Guide Specifications CEGS 03510

Technical Support

- FM I-90 Wind Uplift
- FM Serial Report No. OC2AO-AC
- U.L. Wind Uplift Construction No. 143
- U.L. Wind Uplift Construction No. 150
- U.L. Fire Rated Designs

TABLE 3-U.L. FIRE RATED SYSTEMS

P405	3 hours	P902	2 hours	P923	2 hours
P406	3 hours	P905	2 hours	P231	1-1/2 hours
P215	2 hours	P907	2 hours	P513	1-1/2 hours
P241	2 hours	P908	2 hours	P919	1-1/2 hours
P251	2 hours	P910	2 hours	P214	1 hour
P407	2 hours	P913	2 hours	P216	1 hour
P410	2 hours	P916	2 hours	P246	1 hour
P708	2 hours	P920	2 hours	P509	1 hour
P810	2 hours	P921	2 hours	P511	1 hour
P812	2 hours	P922	2 hours	P678	1 hour
				P903	1 hour

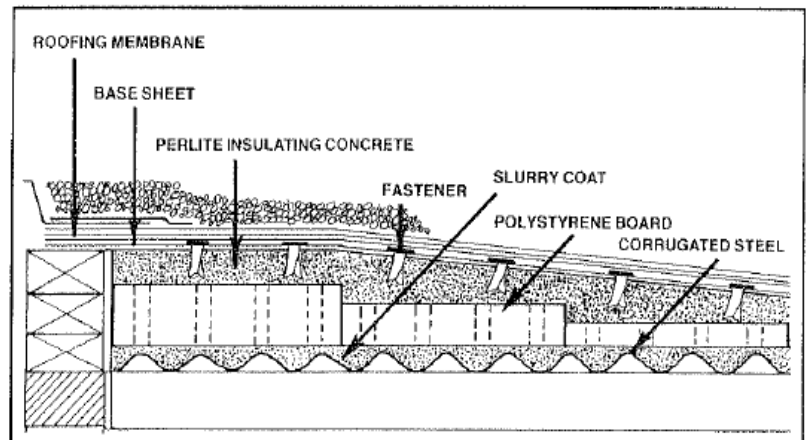

TABLE 4 - TYPICAL PHYSICAL PROPERTIES ** AND MIX PROPORTIONS FOR PERLITE CONCRETE

TYPICAL PROPERTIES				TYPICAL MIX PROPORTIONS			
CEMENT TO AGGREGATE RATIO (BY VOLUME)	DRY DENSITY RANGE lb/ft ³	MINIMUM COMPRESSIVE STRENGTH lb/in ²	WET DENSITY RANGE lb/ft ³	CEMENT ft ³	PERLITE ft ³	WATER gallons	AEA †
1:4	36-42	300	48-56	6.75	27	61	†
1:6	24-30	125	38-44	4.5	27	54	†

* Pittsburgh Testing Laboratory and R.W. Hunt Co. Engineers.
 ** All values based on 28 day test results.
 † Consult perlite manufacturer for recommended type and proportioning of air entraining agent

TABLE 5 - CALCULATIONS FOR R_t AND U-FACTOR

EXAMPLE: 2 in. (51mm) of 27 lb/ft³ (432 kg/m³) perlite concrete fill and 1 in. (25mm) polystyrene insulation board placed over 26 gauge steel form with acoustical tile ceiling.

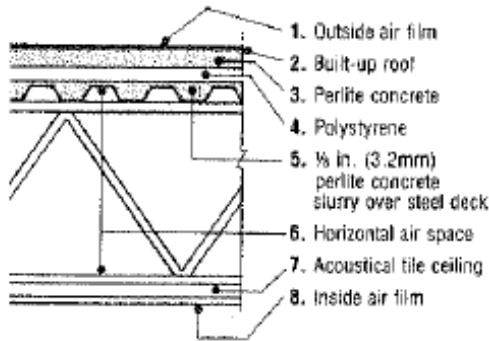

	R Values* Heat Flow Down (Summer)	R Values* Heat Flow Up (Winter)
1	0.25	0.17
2	0.33	0.33
3	3.13	3.13
4	3.85	3.85
5	0.93	0.93
6	1.23	0.85
7	1.79	1.79
8	0.92	0.61

R _t	12.43	11.66
U	0.087	0.09

U-Factor = 1/R_t

*R values expressed in Btu/h•ft²•°F units

GUIDE SPECIFICATION

Scope

An applicator, approved by a perlite manufacturer, shall furnish all labor, materials and equipment for installing the perlite concrete roof insulation and metal decking (where applicable) in accordance with these specifications.

Work by Others

All framings for openings, edge angles, pitch pans, wood hangers, structural expansion joints, vented flashings and stack vents shall be furnished and installed by others.

Inspection

The applicator shall be responsible for inspection and acceptance of the substrate as being suitable to receive the perlite concrete roof insulation system.

PRODUCTS

Materials

- A. Perlite: shall conform to ASTM C 332 Group 1
- B. Portland Cement: shall conform to ASTM C 150 Type I, II or III.
- C. Water shall be clean and free of deleterious substances.
- D. Air Entraining Agent: Neutralized vinsol resin or other air entraining agent as recommended by the perlite manufacturer.
- E. Polystyrene shall be one pound per cubic foot minimum density, conforming to ASTM C578 and include keying holes of approximately 3% of the gross area.
- F. Metal Deck (when applicable) shall be galvanized, ASTM A 525, G60 minimum, and may have vented side laps or slots. The deck shall be _____ type: _____ gauge.
- G. Reinforcing Mesh (only required on some fire rated systems): shall be Keydeck style 2160-2-1619, or approved other.

Physical Properties

Standard Mix

- A. Cement to Aggregate Ratio (by Volume).....1:6
- B. Min. Compressive Strength.....125 psi
- C. Density at Placement.....38-44 pcf
- D. Oven Dry Density.....24-30 pcf

See Table 4 for other properties.

EXECUTION

Installation

- A. The perlite concrete roof insulation shall be installed by a properly equipped and trained applicator approved by the perlite manufacturer. The *perlite* concrete shall be screeded to a surface suitable for application of the roofing. Thickness of perlite concrete shall be as shown on the drawings. (Note: 2 inch minimum thickness recommended for 1:6 mix, 1-1/2 inch minimum for 1:4 mix.)
- B. Polystyrene boards shall be placed in a 1/8 inch minimum slurry coat and covered with a top layer of perlite concrete as soon as practical.
- C. Metal deck (where applicable) shall be installed in accordance with manufacturer's recommendations and local building codes.
- D. Reinforcing Mesh (in some fine rated assemblies) shall be placed at right angles to structural supports with 6 inch side laps. E. Expansion Joints. Perlite concrete roofdecks require only those expansion joints normally used for sound building design, such as where there is a change in direction of decking on independent structural roof members. In all cases, expansion joints are to be through the entire roofdeck/roof assembly.

NOTES TO THE SPECIFIER

Design for Slope

A minimum slope of 1/8 inch per foot is recommended for proper drainage and maximum roofing performance. Sloping the perlite concrete roof insulation system is most economically accomplished by stair stepping the polystyrene boards in 1 inch increments. Indicate the high and low point elevations desired on the roof plan.

Seismic or Diaphragm Design

When the roof deck is designed as a diaphragm, consult the metal deck manufacturer or the Steel Deck Institute Diaphragm Design Manual regarding welding patterns and other design criteria.

Admixtures

Calcium chloride or any admix containing chloride salts shall not be used in perlite concrete roof insulation systems. Use only admixtures recommended by the perlite manufacturer.

Roofing

- A. Consult built-up roofing or single-ply manufacturers for their specific recommendations and specifications for roofing over perlite concrete roof insulation.
- B. Over non-vented substrates, provisions for venting must be made at perimeter flashing or with the use of stack vents. For details contact the perlite manufacturer.
- C. Nail holding power of perlite concrete roof insulation is a prime criteria. Type of nail to be used is the prerogative of the roofing manufacturer. However, a minimum nail holding power of 40 pounds per fastener is recommended.
- D. Perlite concrete roof insulation may be roofed within 48-72 hours from time of placement if it is sufficiently dry and can support workmen without causing surface damage.

Reroofing (when applicable)

Existing roof insulation should be inspected for soundness and moisture content. Pay particular care to the support structure of the building to determine it is capable of safely supporting new roof loads. All loose gravel and dirt shall be swept off the existing roof. For maximum roofing performance, it is recommended that positive drainage be provided by stair stepping polystyrene board.



Perlite Institute, Inc.

4305 North Sixth Street, Suite A, Harrisburg, PA 17110

717.238.9723 / fax 717.238.9985 / www.perlite.org

Technical data given herein are from sources considered reliable, but no guarantee of accuracy can be made or liability assumed. Your supplier may be able to provide you with more precise data. Certain compositions or processes involving perlite may be the subject of patents.